

REVISIONS				
REV.	DESCRIPTION	NCR/ECO NO.	REVISED BY	DATE
A	FOR FABRICATION		T. BAILEY	10/6/2014

BOM TABLE						
ITEM NO.	QTY.	PART NAME	MATERIAL	LENGTH	PART NUMBER	AREA
1	1	Ø 18" PIPE STUB W/ MOUNTING FLANGE	FRP (HLU, POLYESTER)		FGWM018-01	
2	1	18" FG SEAL FLANGE PLATE	FRP (HLU, POLYESTER)		318-0001	424.125
3	1	18" FLAP SEAL W/ INT. STEEL PLATE			512-0009	
4	1	18" FG CLAMPING BAR	FRP (HLU, POLYESTER)		318-0001	30
5	8	5/16 FLAT WASHER	T-304 S/S		664-0029	
6	4	HEX HEAD CAP SCREW, 5/16-18UNC X 1 3/4" LG.	T-304 S/S		661-0138	
7	4	NYLON-INSERT HEX LOCK NUT 5/16-18UNC (McMASTER #91831A030)	T-304 S/S		663-0059	

- NOTES:
- GEL COAT THE EXTERIOR OF THE FINISHED ASSEMBLY SURFACES GRAY WITH SURFACING AGENT. DO NOT GEL COAT SEATING SURFACES.
  - RESIN FOR HAND LAYUPS: MCWHORTER 712-3765 (POLYESTER).
  - JOIN FLAP SEAL FLANGE TO PIPE W/ PLEXUS MA-300 THEN OVERLAY WITH HLU (M,M,M) TO ACHIEVE REQUIRED FINISH THICKNESS.
  - STUB FLANGE BOLT HOLES TO STRADDLE CENTERLINE.
  - CRACKING PRESSURE FOR FLAP GATE ASSEMBLY IS <.25PSI (1/4PSI).

<b>PROJECT:</b> MASTERS TUALATIN, OREGON, USA		 TUALATIN, OR.	<b>PLASTI-FAB PART NUMBER:</b> FGM018		<b>TITLE:</b> 18" FLAP GATE ASSEMBLY, FLANGE MOUNT TYPE	
<b>CUSTOMER:</b> PLASTI-FAB, INC.			<b>MATERIAL INFORMATION:</b>			
<b>REP:</b>		UNLESS OTHERWISE SPECIFIED, DIMENSIONS ARE IN FEET/INCHES		<b>SPECIAL FINISH REQUIREMENT:</b> ERROR!:FINISH		
<b>P.O. NO.:</b>		TOLERANCES UNLESS OTHERWISE SPECIFIED.		<b>NAME:</b>		
<b>PROPRIETARY AND CONFIDENTIAL</b> THE INFORMATION CONTAINED IN THIS DRAWING IS THE PROPERTY OF PLASTI-FAB. ANY REPRODUCTION IN PART OR AS A WHOLE WITHOUT THE WRITTEN PERMISSION OF PLASTI-FAB IS PROHIBITED.		≤ 6'-0"	± 1/16"	<b>DATE:</b>	<b>SIZE</b>	
		> 6'-0" AND ≤ 25'-0"	± 1/8"	T. BAILEY	<b>B</b>	
		> 25'-0"	± 1/2"	10/6/2014	<b>DRAWING NO.:</b>	
		<b>DRAWN BY:</b>			FGFM018	
		<b>CHECKED BY:</b>			<b>REV. A</b>	
				<b>WEIGHT:</b> 49	<b>SCALE:</b> 1:4	
				<b>SHEET:</b> 1 OF 6		

REVISIONS				
REV.	DESCRIPTION	NCR/ECO NO.	REVISED BY	DATE
A	FOR FABRICATION		T. BAILEY	10/6/2014

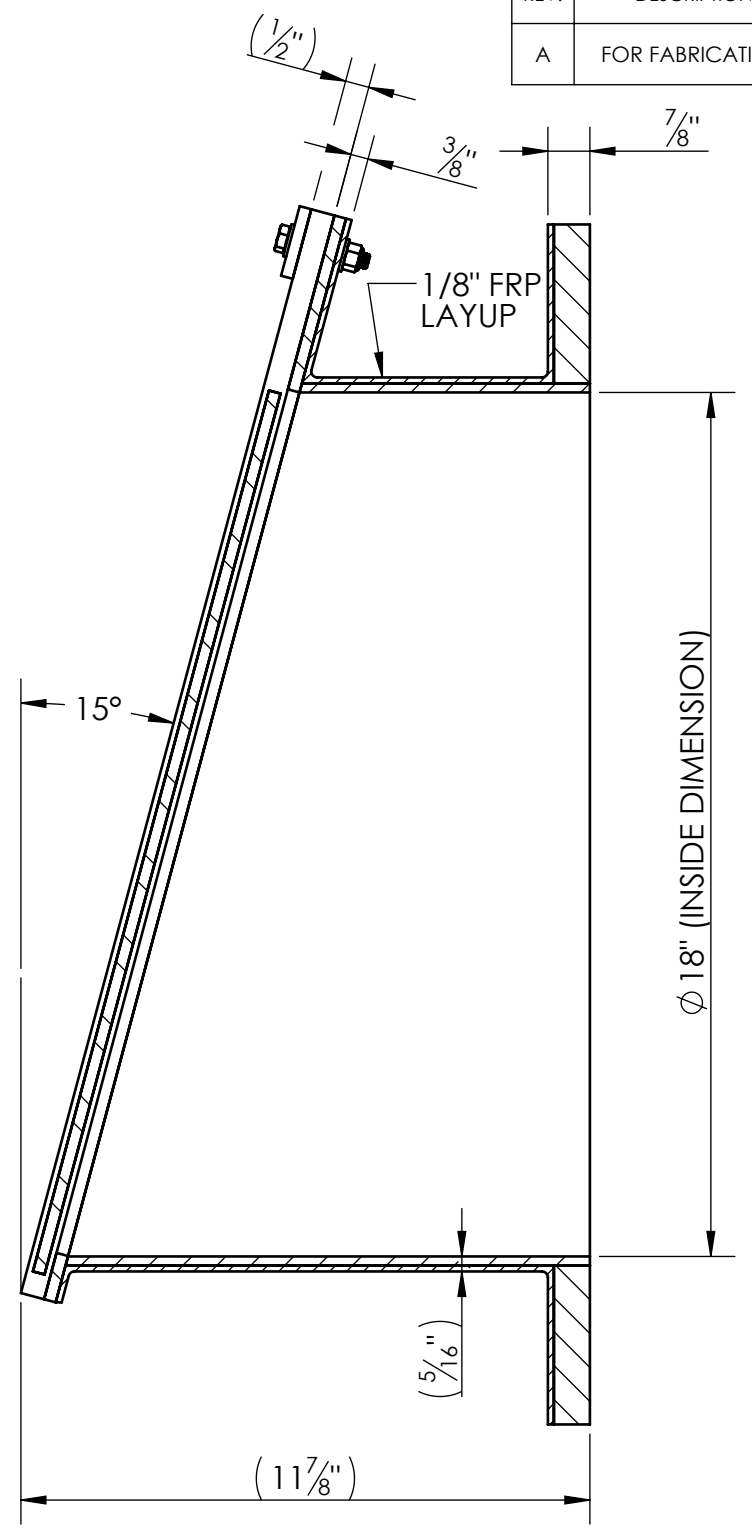
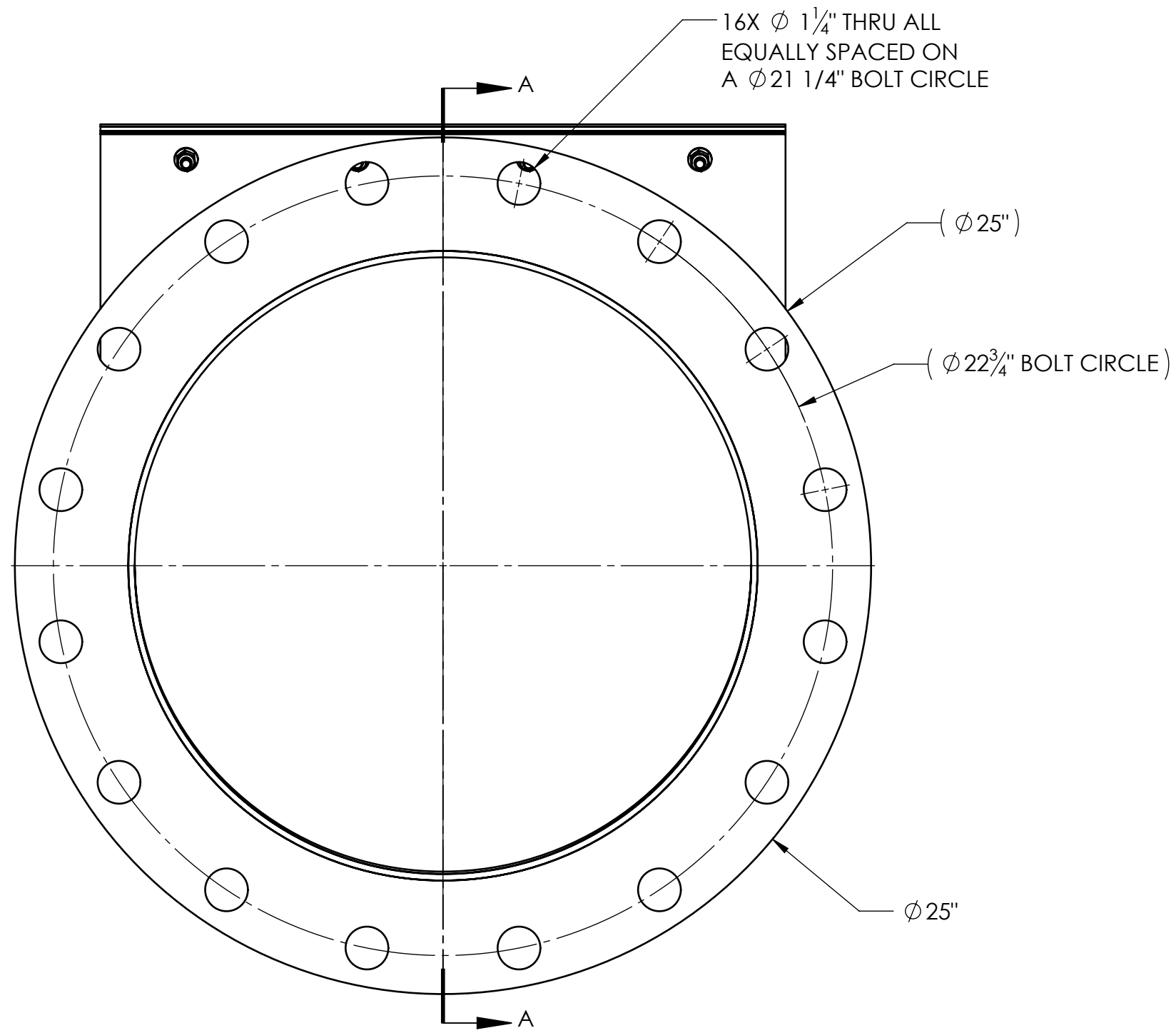

THICKNESSES GIVEN ARE FINISHED AFTER FRP LAMINATE

SECTION A-A

- NOTE:
1. THINNER MATERIAL IS ACCEPTABLE FOR PIPE MOUNTING FLANGE AND FG SEAL FLANGE AS LONG AS 1/8" LAMINATE IS USED TO BOND PIECES TO PIPE AND FINAL FLANGE THICKNESS IS ACHIEVED.
  2. GRIND INTERIOR TRANSITION BETWEEN PIPE & FG SEAL FLANGE FLAT TO ELIMINATE FLOW INTERFERENCE.

PROJECT: MASTERS TUALATIN, OREGON, USA	 TUALATIN, OR.	PLASTI-FAB PART NUMBER: FGFM018	TITLE: 18" FLAP GATE ASSEMBLY, FLANGE MOUNT TYPE		
CUSTOMER: PLASTI-FAB, INC.		MATERIAL INFORMATION:	SIZE B	DRAWING NO.: FGFM018	REV. A
REP:	UNLESS OTHERWISE SPECIFIED, DIMENSIONS ARE IN FEET/INCHES	SPECIAL FINISH REQUIREMENT: ERROR!:FINISH	NAME:	DATE:	WEIGHT: 49
P.O. NO:	TOLERANCES UNLESS OTHERWISE SPECIFIED.	ERROR!:FINISH	DRAWN BY: T. BAILEY	10/6/2014	SCALE: 1:4
PROPRIETARY AND CONFIDENTIAL THE INFORMATION CONTAINED IN THIS DRAWING IS THE PROPERTY OF PLASTI- FAB. ANY REPRODUCTION IN PART OR AS A WHOLE WITHOUT THE WRITTEN PERMISSION OF PLASTI-FAB IS PROHIBITED.	$\leq 6'-0"$ $\pm 1/16"$ $> 6'-0"$ AND $\leq 25'-0"$ $\pm 1/8"$ $> 25'-0"$ $\pm 1/2"$	TOLERANCES UNLESS OTHERWISE SPECIFIED. $\leq 6'-0"$ $\pm 1/16"$ $> 6'-0"$ AND $\leq 25'-0"$ $\pm 1/8"$ $> 25'-0"$ $\pm 1/2"$	CHECKED BY:		SHEET: 2 OF 6