

REVISIONS				
REV.	DESCRIPTION	NCR/ECO NO.	REVISED BY	DATE
A	INITIAL RELEASE		T. BAILEY	4/30/2013
B	GENERAL REVISION; UPDATED BOM LIST DESCRIPTION & PART NUMBERS		T. BAILEY	11/8/2013

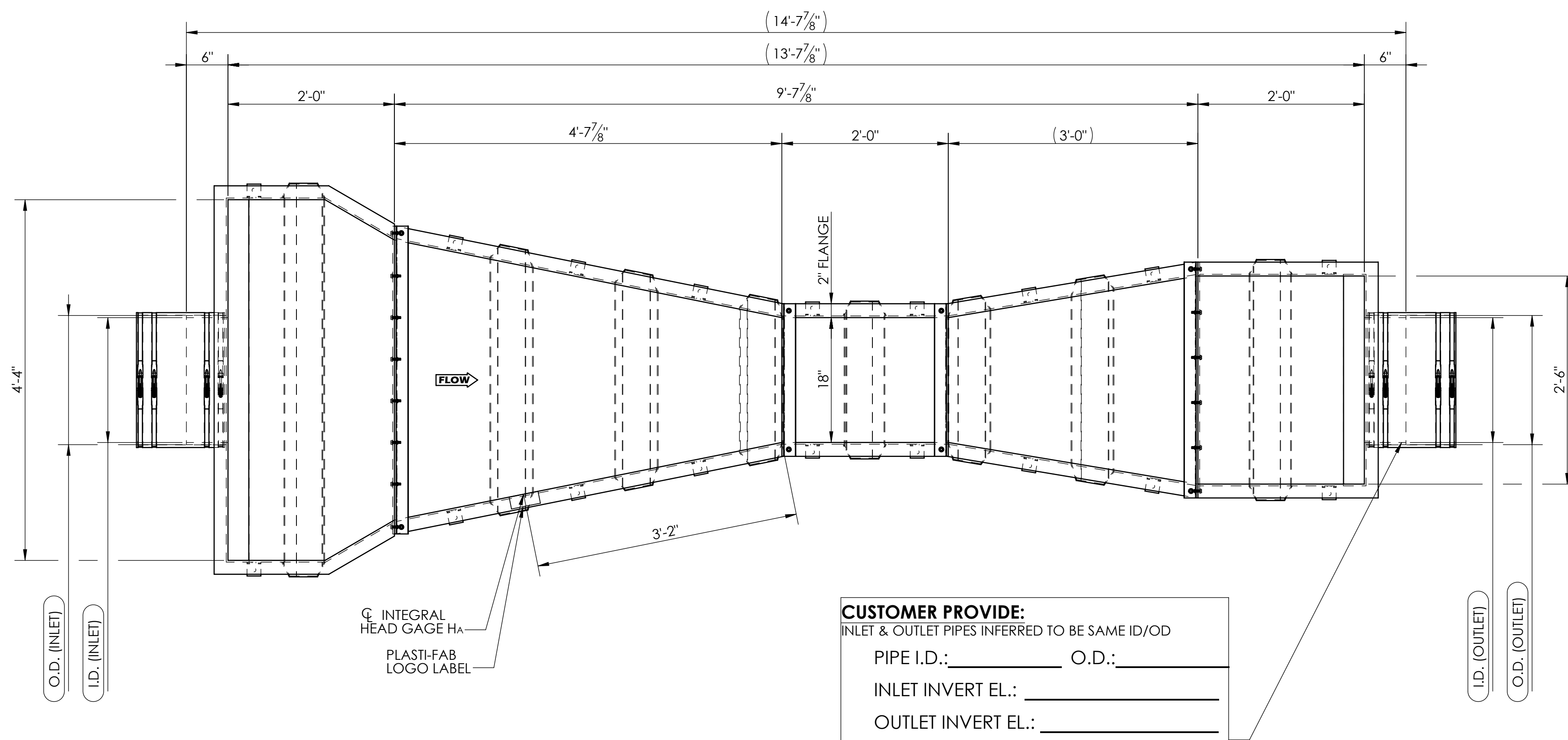

CUSTOMER PROVIDE:
 INLET & OUTLET PIPES INFERRED TO BE SAME ID/OD
 PIPE I.D.: _____ O.D.: _____
 INLET INVERT EL.: _____
 OUTLET INVERT EL.: _____

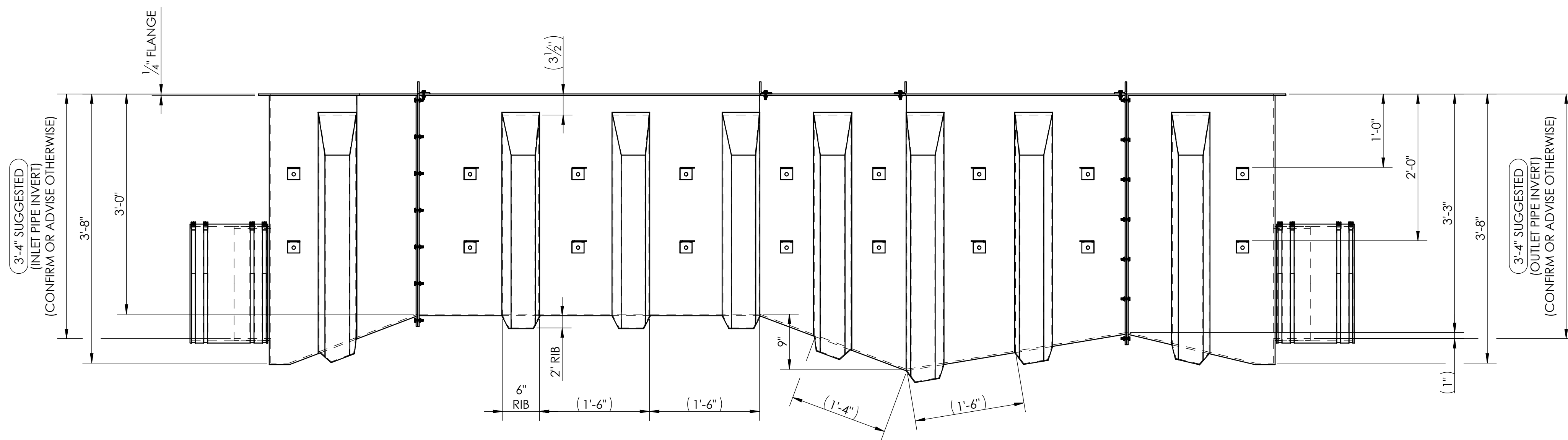
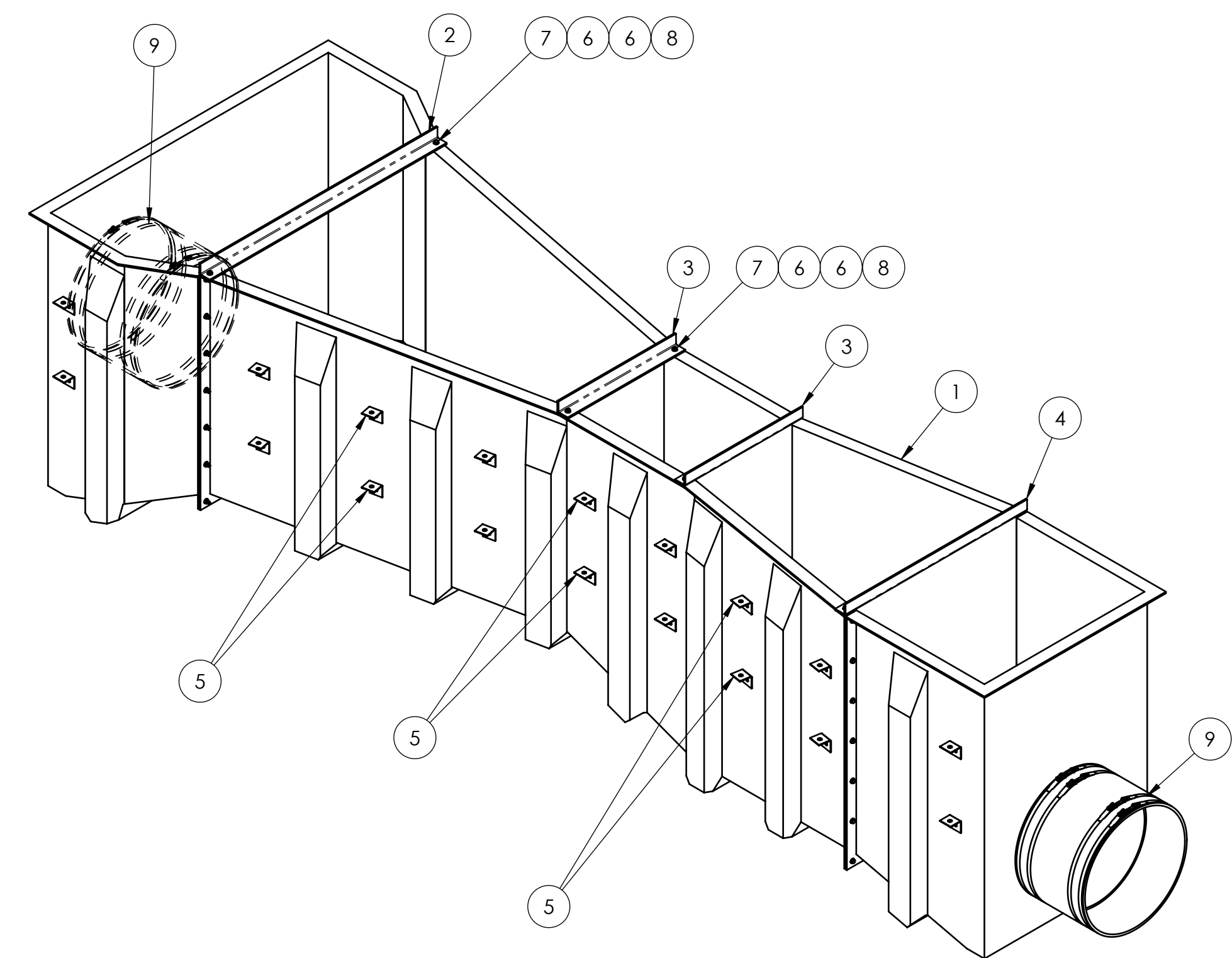

- NOTES:**
- THE MINIMUM THICKNESS IS 1/4" FRP (FIBERGLASS REINFORCED PLASTIC).
 - THE INSIDE SURFACE IS SMOOTH WHITE GEL COAT.
 - THE OUTSIDE SURFACE IS WHITE GEL COAT.
 - MINIMUM GLASS CONTENT IS 30%, EXCLUSIVE OF RESIN RICH SURFACES.
 - THE HEAD GAGE (100THS OF A FOOT & CENTIMETERS) IS MOLDED INTO THE SIDE OF THE FLUME.
 - PLACE LARGE FLOW DIRECTION ARROW DECAL ON BOTTOM OF FLUME @ APPROXIMATELY 3" FROM INLET END.
 - PLACE PLASTI-FAB LOGO LABEL ON TOP FLANGE AT APPROXIMATE CENTER-LINE OF MEASUREMENT POINT OR GAGE LOCATION.
 - KEYTAB CLIPS TO BE LOCATED AS SHOWN AT APPROXIMATE CENTER OF AREA.
 - CUSTOMER TO SUPPLY INLET & OUTLET PIPE I.D. & O.D. DIMENSIONS.**
 - INLET PIPE INVERT & OUTLET PIPE INVERT WILL BE SUPPLIED SET TO THE DIMENSIONS SHOWN UNLESS OTHERWISE SPECIFIED BY CUSTOMER.**
 - SIZE OF BOOTS & BAND WILL BE DETERMINED FROM CUSTOMER SUPPLIED PIPE STUB O.D. DIMENSION.**
 - RESIN: CCP STYPOL C1-1200-22.

APPROVED AS NOTED

Name	Company
Signature	Date

Job No.

BOM TABLE					
ITEM NO.	005/QTY.	DESCRIPTION	MATERIAL	LENGTH	PART NUMBER
1	1	18" PARSHALL FLUME WITH END ADAPTERS & PIPE STUBS	FRP (HLU, POLYESTER)	-	PF018-04
2	1	SPREADER ANGLE, 2" x 2" x 1/4"	FRP (PULTRUDED, POLYESTER)	3'-8 3/8"	312-0013
3	2	SPREADER ANGLE, 2" x 2" x 1/4"	FRP (PULTRUDED, POLYESTER)	1'-10"	312-0013
4	1	SPREADER ANGLE, 2" x 2" x 1/4"	FRP (PULTRUDED, POLYESTER)	2'-10"	312-0013
5	36	2" KEYTAB CLIP	A36		410-0007
6	16	5/16 FLAT WASHER	T-304 S/S	-	664-0029
7	8	HHCS, 5/16-18UNC X 1 1/4"	T-304 S/S	-	661-0366
8	8	HEX NUT, 5/16-18UNC	T-304 S/S	-	663-0001
9	2	CUSTOMER PROVIDE PIPE OD FOR BOOT WITH S/S BANDS	NEOPRENE	-	-

PROJECT: 24" PARSHALL FLUME STANDARDS TUALATIN, OREGON USA CUSTOMER: PLASTI-FAB, INC. REP: P.O. NO.: PROPRIETARY AND CONFIDENTIAL THE INFORMATION CONTAINED IN THIS DRAWING IS THE SOLE PROPERTY OF PLASTI-FAB. ANY REPRODUCTION IN PART OR AS A WHOLE WITHOUT THE WRITTEN PERMISSION OF PLASTI-FAB IS PROHIBITED.	TUALATIN, OR.	PLASTI-FAB PART NUMBER: MATERIAL INFORMATION: SPECIAL FINISH REQUIREMENT:	TITLE: 18" PARSHALL FLUME ASSEMBLY WITH END ADAPTERS, PIPE STUBS, & BOOTS & BANDS
		TOLERANCES UNLESS OTHERWISE SPECIFIED: ≤ 6'-0" ± 1/16" > 6'-0" AND ≤ 25'-0" ± 1/8" > 25'-0" ± 1/2"	NAME: T. BAILEY DATE: 5/7/2013 DRAWN BY: T. BAILEY CHECKED BY:

WEIGHT: 426 SCALE: 1:12